

BRITE BOX™ SD8 KIT - INSTALLATION INSTRUCTIONS

Made In U.S.A.

www.thebritebox.com

U.S. Pat. Pend.

The BRITE BOX SD8's are fully self contained devices that illuminate your low beams when your high beams are on. This provides you with an even carpet of light that stretches from near to far. Without BRITE BOX, your low beams drop out when your high beams are on.

On many vehicles, you can simulate the operation of the BRITE BOX by activating the "flash to pass" function when your low beams are on. When doing this, you will see an increase in lighting brightness and the quality of the headlight's beam pattern. Many people try to drive like this, but often find out that the headlight switch or wiring of their vehicles burn out since they are not designed to handle these increased loads on a continual basis. With BRITE BOX, you can enjoy the benefits of this improved beam pattern, automatically, without placing any additional loads on the vehicle's stock headlight switches or wiring.

Installation is easily accomplished with common hand tools in a short period of time. In order to make your installation go as smoothly as possible, it is recommended that you read the instructions and plan your installation before starting.

PARTS LIST:

- 2 – Brite Box SD8
- 2 – 10 Amp ATC Fuse
- 16 – Cable (Wire) Ties
- 2 – Alcohol Pads
- 1 – Power Extension Kit
(Used / supplied only for single battery vehicles)

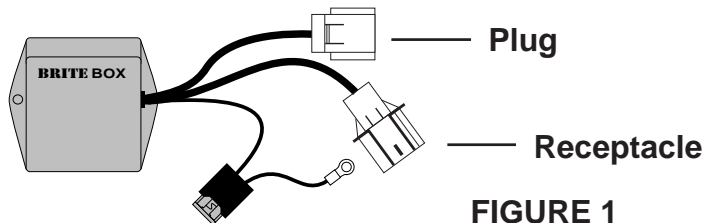

TOOLS REQUIRED:

- Wrench to fit your positive battery post / clamp – usually a 10mm, 13mm, or 1/2 inch.
- 10 mm Socket, Socket Wrench, Long extension
- Wire Cutters, Strippers, and Crimpers (Single battery vehicles only)

STEP 1: INSTALL BRITE BOX ON DRIVER SIDE HEADLIGHT

Figure Reference: Figures 1 & 2

2006 – 2007 DODGE RAM NOTE: HEADLIGHT PLUG CAN BE ACCESSED WITHOUT REMOVING HEADLIGHT, OTHER VEHICLES MAY REQUIRE HEADLIGHT REMOVAL TO ACCESS HEADLIGHT PLUG. SEE OWNER'S MANUAL FOR HEADLIGHT REMOVAL PROCEDURE.

- ⇒ Open hood of vehicle.
 - ⇒ Remove vehicle's headlight plug from headlight bulb (it is NOT necessary to remove bulb from headlight assembly).
Note: Dodge's headlight plugs have a red safety catch that must be released before plug can be removed (See Fig 2).
 - ⇒ Insert Dodge's headlight plug into Brite Box's receptacle (See Fig.1)
 - ⇒ Insert Brite Box's headlight plug into headlight bulb (See Fig.1)
 - ⇒ Mount Brite Box to vehicle using double stick tape (clean mounting surface with supplied alcohol pad) or by wire tying it to an existing harness.
 - ⇒ Be sure to observe UP orientation on Brite Box's label to allow for drainage should water enter unit.
- NOTE: Water damage is not covered under warranty!**
- ⇒ Install 10 Amp fuse into fuse holder.
 - ⇒ Secure all wires in a neat and tidy manner using supplied cable ties.

STEP 2: UNBOLT PASSENGER SIDE HEADLIGHT

NOTE: PICTURES SHOW HEADLIGHT REMOVAL PROCEDURES FOR 2006 – 2007 DODGE RAM. IF INSTALLING INTO DIFFERENT VEHICLE, CONSULT OWNER'S MANUAL FOR HEADLIGHT BULB CHANGE / REMOVAL PROCEDURE.

Figure Reference: Figures 3 and 4

- ⇒ Remove two (2) 10mm bolts in positions shown in FIG 3.
- ⇒ Remove 10mm hex nut from rear of headlight (See Fig 4.) Hex nut can be reached by removing rubber grommet in fender liner. Use a long socket extension to reach it. **Take care not to drop this nut when you remove it.**
- ⇒ "Pop" headlight free from truck by pulling headlight straight out .
- ⇒ When headlight is free, unplug headlight harness from headlight bulb (See Fig. 2) and remove side marker bulb from headlight assembly by twisting it.
- ⇒ Place headlight where it cannot be damaged while you are installing Brite Box.

STEP 3: INSTALL BRITE BOX ON PASSENGER SIDE HEADLIGHT

Figure Reference: Figures 1 & 2

- ⇒ Use same procedures outlined in Step 1 to install Brite Box on passenger side headlight.
- ⇒ When you mount Brite Box, make sure it is mounted far enough back to allow headlight to be reinstalled.
- ⇒ If your vehicle is Diesel powered (two batteries), attach ring on power lead directly to positive terminal on battery.
- ⇒ If your vehicle has a single battery on the driver's side, install PEK (power extension kit) according to the second to last page of these instructions.
- ⇒ Install 10 Amp fuse into fuse holder.

STEP 4: TEST BRITE BOX FOR PROPER OPERATION

- ⇒ Make sure side marker light is installed into passenger headlight assembly.

- ⇒ Make sure Brite Box's headlight plug is installed into headlight bulb of passenger headlight.
- ⇒ Put passenger headlight back into vehicle with "Pop" clip so it does not fall out.
- ⇒ Turn low beams ON.
- ⇒ Turn on HIGH beams on. You will notice greatly improved headlight output and coverage due to the low beams illuminating.

STEP 5: REINSTALL PASSENGER HEADLIGHT

Figure Reference: Figures 3 & 4

- ⇒ When reinstalling headlight, make sure no wires are pinched between headlight assembly and other parts of vehicle!
- ⇒ Replace hex nut and 2 - 10mm bolts to secure headlight to vehicle.
- ⇒ Replace rubber grommet in fender liner.

STEP 6:

- ⇒ Use remaining cable ties to secure all wires in a neat and tidy manner.
- ⇒ Clip loose ends from cable ties.

NOTE: DO NOT USE BRITE BOX WITH SO CALLED "EXTRA OR SUPER BRIGHT BULBS". EXPERIENCE HAS SHOWN THAT THESE BULBS ARE NOT MUCH BRIGHTER THAN STOCK BULBS, BURN OUT QUICKLY, ARE VERY COSTLY AND GENERATE MORE HEAT THAN MOST HEADLIGHT SYSTEMS CAN WITHSTAND. INSTALLING BRITE BOX WITH STANDARD WATTAGE BULBS (120 WATTS OR LESS FOR HIGH + LOW BEAM) PROVIDES SUPERIOR ILLUMINATION (BETTER BEAM PATTERN WITH LESS FATIGUE) THAN A SLIGHTLY BRIGHTER INFERIOR BEAM PATTERN PROVIDED BY THESE "SUPER BRIGHT BULBS".

BECAUSE OF THEIR SUPERIOR QUALITY, MORE AUTO MANUFACTURERS SPECIFY OSRAM / SYLVANIA HEADLIGHT BULBS AS OEM EQUIPMENT THAN ALL OTHER BRANDS COMBINED. OUR EXPERIENCE CONFIRMS THE QUALITY OF OSRAM / SYLVANIA BULBS IN THAT THEY LAST THE LONGEST AND HAVE THE LOWEST FAILURE RATE.

We have seen bulb brands that you should avoid. These brands are WAGNER and GE (General Electric). These brands are poorly designed (in our opinion) in that they use VERY thin wires to deliver current to the bulb filaments. This causes problems in bulb life and reliability. It is common to see these wires break or deform which causes the bulb to prematurely fail. In fact, it is probably best to avoid any headlight bulbs whose reliability you are not sure of.

SOME FREE ADVICE ABOUT HEADLIGHT BULBS:

- Stick with Osram / Sylvania brand bulbs. Don't second guess the car makers.
- Carry spares in your glove box. It's cheap insurance. Changing a bulb usually takes only a few minutes, but you cannot replace a burned out one without a spare. If you have quality spares, you will never have to settle for cheap bulbs because that is the only thing that "Bob's Boonie Market And Service Station" stocks (if any at all).

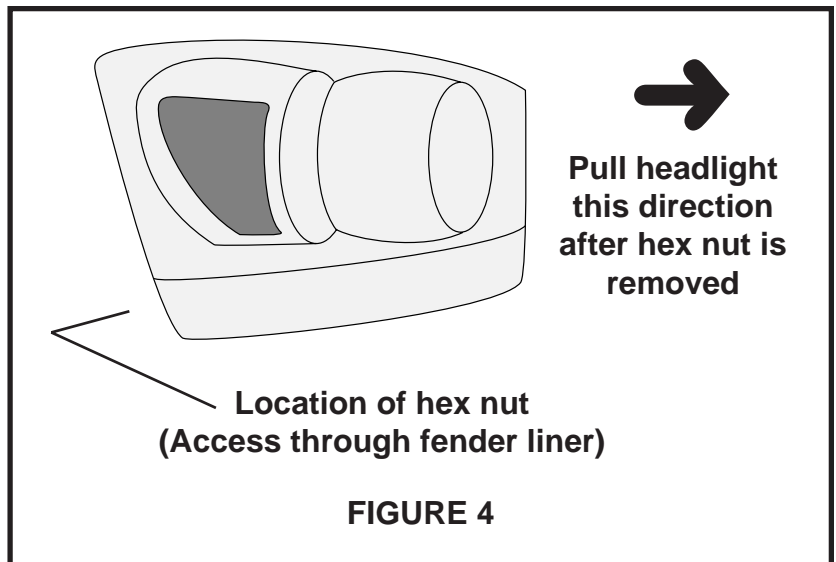
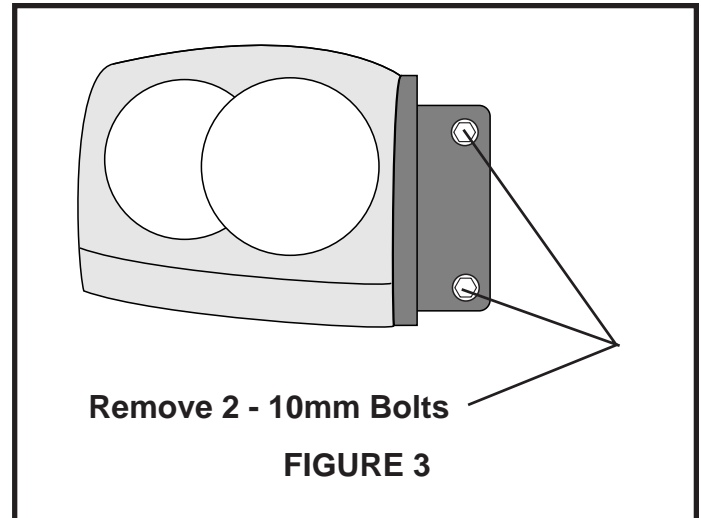
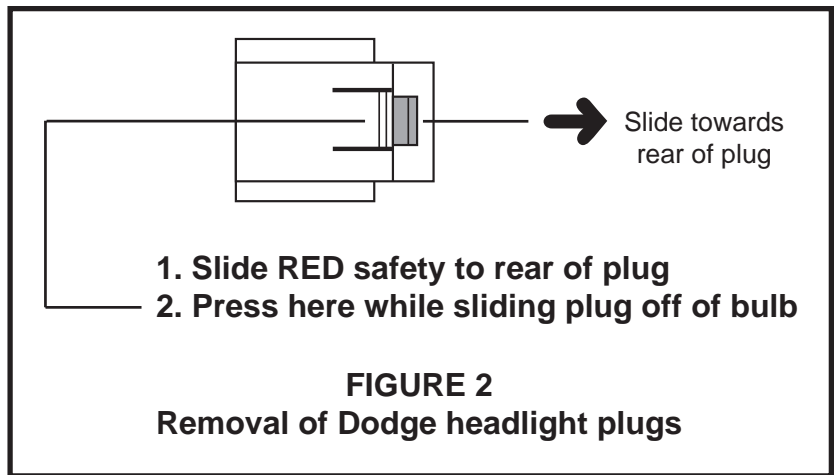

TECH AND ORDER LINE: (970) 879-4201

BAKER AUTO ACCESSORIES

2955 Village Dr. #5 Steamboat Springs, CO 80488 Fax: (970) 879-6097

www.bakerautoaccessories.com

**DOES YOUR VEHICLE HAVE FACTORY INSTALLED FOG LIGHTS?
IF YES, YOU MAY WANT TO CONSIDER UPGRADING THIS KIT TO "FLC"
(Fog Light Control)!**

**FLC UNITS ALSO KEEP THE FACTORY INSTALLED FOG LIGHTS ON WITH
HIGH BEAMS. CALL 970.879.4201 FOR DETAILS!**

BRITE BOX LIMITED WARRANTY

Baker Auto Accessories (B.A.A.) warrants Brite Box to be free from manufacturing defects under normal use and conditions for three (3) years from date of original user purchase.

Baker Auto Accessories, at its sole discretion, will either repair the product or replace the product, provided the manufacturing defect is verified along with proof of purchase. To obtain warrant service call 1-970-879-4201.

This warranty is void if the product is:

- A) Damaged through negligence, misuse, abuse or accident.
- B) Modified, repaired, or tampered with by anyone other than B.A.A.
- C) Units on which the serial number has been defaced, modified or removed.

This warranty does not cover:

- A) Damage due to improper installation.
- B) Water, smoke, or heat damage.
- C) Damage or improper operation of unit caused by customer abuse, misuse, negligence, or failure to follow correct installation procedures as provided with product.
- D) Costs of shipping of the product to and from B.A.A.

This warranty is non-transferable and applies only to the original purchaser and does not extend to subsequent owners of the product. Any applicable implied warranties, including the warranty of merchantability, are limited in duration to a period of the expressed warranty as provided herein beginning with the date of original purchase at retail and no warranties, whether expressed or implied, shall apply to the product thereafter. Baker Auto Accessories makes no warranty as to the fitness of the product for any particular purpose or use.

The extent of Baker Auto Accessories' liability under this limited warranty is the repair or replacement provided above and, in no event, shall Baker Auto Accessories' liability exceed the purchase price paid by the purchaser of the product. Under no circumstances shall Baker Auto Accessories be liable for any loss, direct, indirect, incidental, special, or consequential damage arising out of or in connection with the use of this product.

BRITE BOX POWER EXTENSION KIT

PART NO. PEK

Some vehicles require a Brite Box unit for each headlight. This kit allows you to extend the power lead on a Brite Box so that it can reach the battery located on the other side of the vehicle.

KIT CONTENTS:

1 – Power Wire

2 – Blue Butt Connectors

2 – Pieces of Shrink Tubing

TOOLS REQUIRED:

Heat gun or butane lighter

Wire Crimpers, Cutters & Strippers

INSTALLATION INSTRUCTIONS:

STEP 1 : CUT fuse holder off of Brite Box midway between Brite Box enclosure and fuse holder body.

STEP 2: Attach ring of fuse holder directly to positive(+) battery terminal.

STEP 3: Strip insulation off of loose end of fuse holder and one end of supplied power wire. Connect wires together using supplied butt connector. Place shrink tubing over butt connector and use lighter or heat gun to shrink.

STEP 4: Run power wire across vehicle (over radiator brace or behind bumper) to location where you are going to mount the Brite Box.

STEP 5: Use supplied wire ties to secure wire where necessary. **MAKE SURE WIRE CANNOT BECOME TANGLED IN RADIATOR FAN!**

STEP 6: Cut power wire to appropriate length and attach to Brite Box. Repeat connection procedure used in STEP 3.

